

Cerberus™ PRO

FS720 fire detection system with integrated single-sector extinguishing

XCI2005-A1, XT2001-A2, XCM7202-Z3



Integrated, modular single-sector extinguishing for FS720 fire control panels in Comfort and Large housing.

- Single-sector extinguishing extension for FS720 fire detection system
- Combined fire detection and extinguishing
- Conforms to EN 12094-1, VdS 2496 and VdS 3844
- Standalone extinguishing control panel possible
- Integrated or remote extinguishing terminal
- Configuration of fire detection and extinguishing extension in a joint application
- Integration in C-WEB/SAFEDLINK network
- An integrated primary extinguishing terminal and a maximum of 5 remote extinguishing terminals

Properties

- Scalable, modular structure
- High-pressure extinguishing compatible with the entire Sinorix portfolio
- Configurable valve and actuator outputs
- Blockable standard outputs for 'Emergency hold' and 'Emergency abort'
- Configurable activation and delay times
- Monitored 'Loss of agent' inputs and pressure switch
- Monitored inputs and outputs
- Monitoring for short-circuit, open line, and ground fault
- Extensive EMC protection
- Valve outputs can be calibrated without end-of-line (EOL) element
- All control panel functions, such as event log and text display, are supported
- Simple maintenance due to deactivation functions
- Test functions
- Optional key switch for access restriction
- Complete support of the addressed detector lines

The FS720 extinguishing extension is a single-sector extinguishing application, which can be integrated into the following control panels and housings:

- FC722 and FC724 fire control panels in the comfort or large housing with power supply (250 W)
- The FS720 extinguishing extension is suitable for replacing or updating existing applications with XC10 systems.

Use

Integrated single-sector extinguishing

The single-sector extinguishing function with an FS720 fire control panel can be integrated within the FC722 and FC724 with a 250-W power supply in the comfort and large housing where this has sufficient space for installation of the extinguishing components.

The following variants are possible:

- Standalone control panel with one flooding zone
- Networked control panels with one flooding zone each

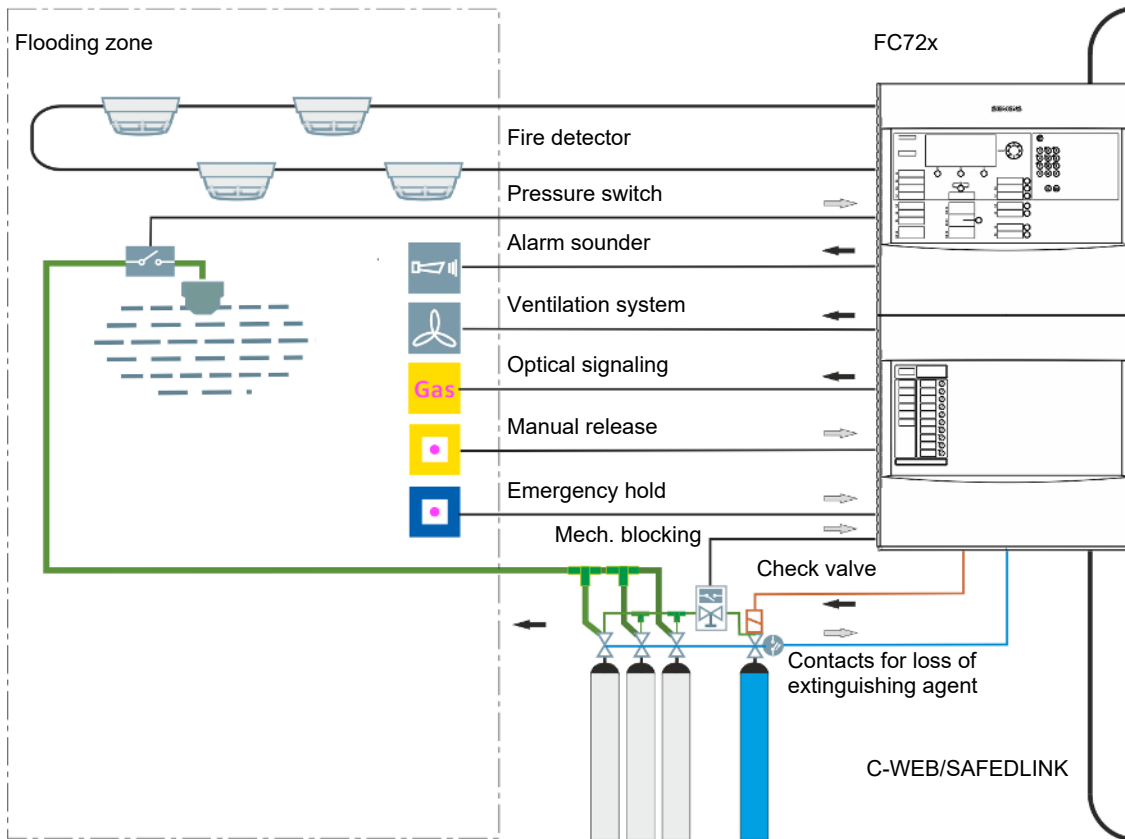
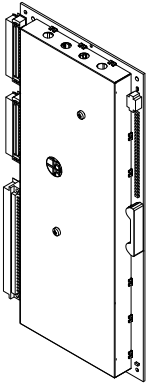
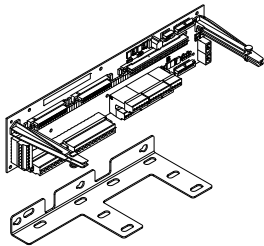
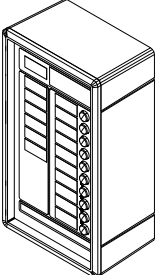
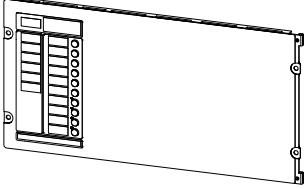
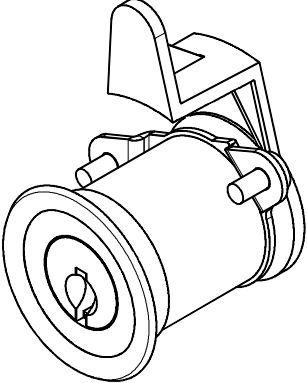
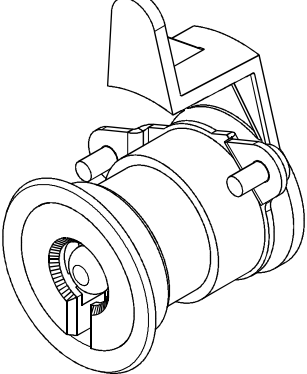
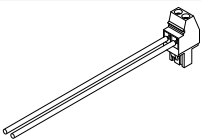

Fig. 1: Example: Single-sector extinguishing with monitoring and control from one fire control panel

Structure and function

<p>XCI2005-A1</p> 	<p>Exting. card</p> <p>The extinguishing card XCI2005 is a module bus card for single-sector extinguishing for installation in FC722 and FC724 control panels in the Comfort housing.</p> <p>Properties</p> <ul style="list-style-type: none"> • For single-sector extinguishing • 10 monitored outputs, can be configured as follows: <ul style="list-style-type: none"> – Valve output – Alarm output (acoustic or optical alarm devices) – Inverse output (e.g., for door magnets) • The following peripheral devices can be connected: <ul style="list-style-type: none"> – Group valves, reserve group valves – Control valves, reserve control valves – Reserve emergency stop valve – Extended discharge extinguishing valve – Isolated group valve • 4 monitored collective inputs for up to 8 devices • All collective inputs can be configured as monitored inputs • 6 monitored inputs • Inputs can be configured for 5 different circuits ('Normally open', 'Normally closed', 'Simple switchable', 'Complex switchable', 'Loss of agent') • 6 open drain outputs • 1x supply output DC 24 V for 'open drain' outputs • Connection for 1x primary extinguishing terminal • Connection for max. 5x secondary extinguishing terminals
<p>FCA2046-A1</p> 	<p>Card cage (1 sector exting.)</p> <p>The card cage (1 sector exting.) FCA2046 is a carrier for an extinguishing card with plug-in contacts for internal and external signal transmission to the extinguishing terminals.</p> <p>The FCA2046 is designed for mounting in FC722 and FC724 fire control panels in the Comfort housing. The scope of delivery includes a metal container for securing the cables.</p>
<p>XT2001-A2</p> 	<p>Extinguish. terminal (remote)</p> <p>Remote extinguishing terminal for one flooding zone.</p> <ul style="list-style-type: none"> • Required as a primary extinguishing terminal for fire control panels if no space is available for installation of a primary extinguishing terminal. • Can be connected as a secondary extinguishing terminal in addition to the primary extinguishing terminal. A maximum of five secondary extinguishing terminals can be connected per flooding zone. • Prepared for installation of a key holder.

<p>XCM7202-Z3</p> 	<p>Exting. terminal (1 sector)</p> <p>Operating add-on with extinguishing terminal for one flooding zone. For installation in one FS720 fire control panel with single-sector extinguishing.</p>
<p>XTO2002-C1</p> 	<p>Key switch (Kaba)</p> <p>The key switch (Kaba) XTO2002 is a country-specific option for installation in an extinguishing terminal.</p>
<p>XTO2003-B1</p> 	<p>Key switch (nordic)</p> <p>The key switch (nordic) XTO2003 is a country-specific option for installation in an extinguishing terminal for the Nordic countries.</p>
<p>FCA2047-A1</p> 	<p>Accessories kit (FCA2046)</p> <p>Accessories kit for the card cage (1 sector exting.) FCA2046 for single-sector extinguishing control panels with 400 mm power supply cable, 5x spacers M3 x 6.5, and cable ties.</p>

Designs

Fire control panel for single-sector extinguishing

The components for single-sector extinguishing can be integrated in all fire control panels FC722 and FC724 in the Comfort and Large housing with 250 W power supply, provided there is enough space for installation.



The card cage for the extinguishing card can only be installed in fire control panels from IP7 onward.

The following fire control panel FC724-ZA provides an example of the installation situation.

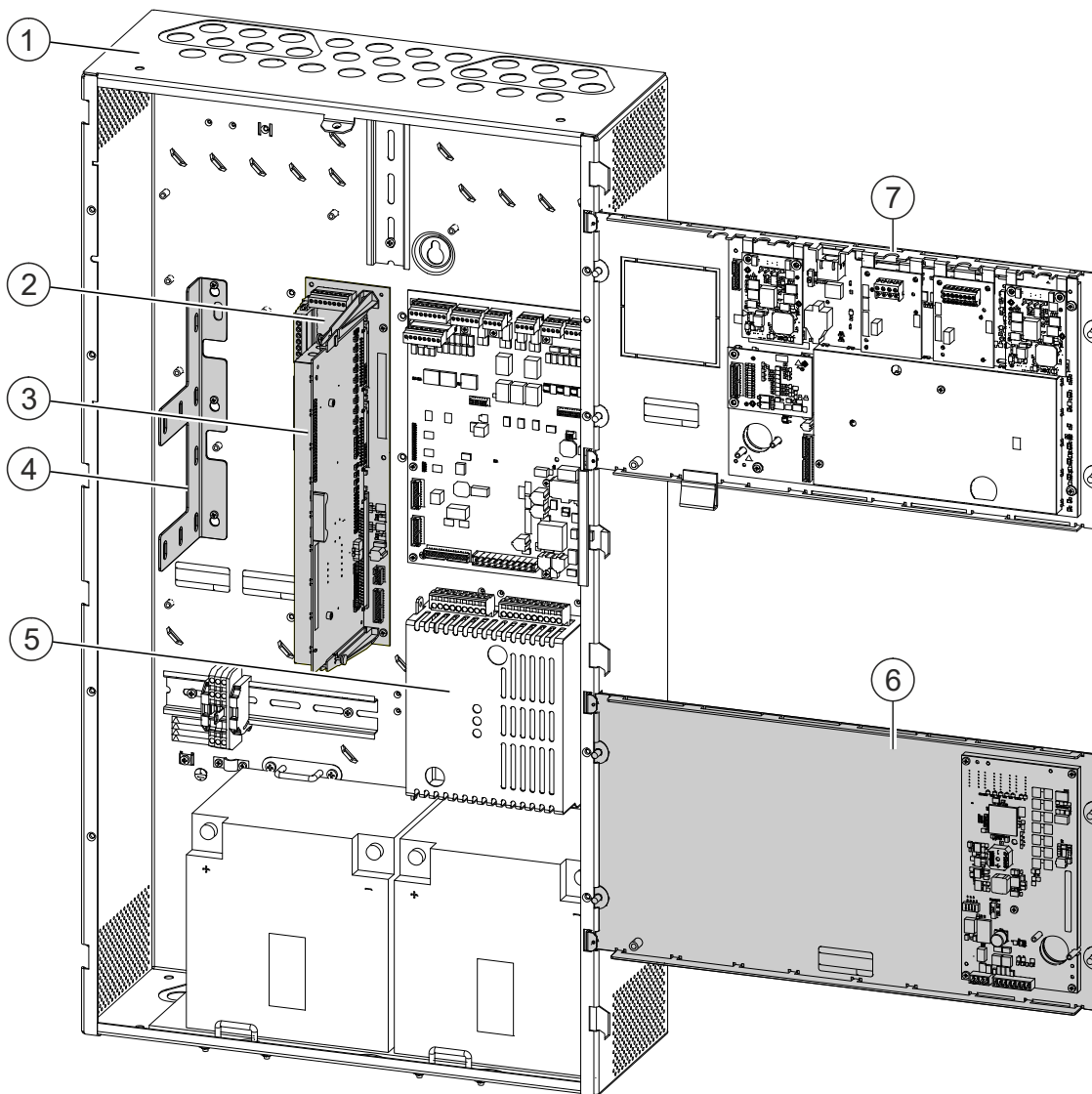

Fig. 2: FC724-ZA with extinguishing card and one extinguishing terminal

- 1 Fire control panel FC724-ZA in the Comfort housing
- 2 FCA2046 card cage (1 sector exting.)
- 3 XCI2005 extinguishing card
- 4 Metal bracket for cable attachment (FCA2046 scope of supply)
- 5 Power supply (250 W)
- 6 XCM7202-Z3 exting. terminal (1 sector)
- 7 Operating unit

Type Overview

Extinguishing components

Type	Order number	Designation
XCA2005-A1	S54392-S20-A1	Extinguishing control kit (1 sector): FCA2006-A1, FCA2046-A1, XCI2005-A1, FCA2047-A1
XCI2005-A1	S54392-A7-A1	Exting. card
FCA2046-A1	S54392-B8-A1	Card cage (1 sector exting.)
XCM7202-Z3	S54392-B18-A1	Exting. terminal (1 sector), including 1 pre-assembled connection cable L=1400 mm
XT2001-A2	S54392-F2-A1	Extinguish. terminal (remote), customer connection cable

Accessories

Accessories for extinguishing control panels

Type	Order number	Name/comment
XTO2002-C1	S54392-B12-A1	Key switch (Kaba)
XTO2003-B1	S54392-B11-A1	Key switch (nordic)
FCA2047-A1	S54392-S17-A1	Accessories kit (FCA2046) Power supply cable, spacers, and attachment material for 1-sector extinguishing control panel

Device combinations

FS720 fire control panels with single-sector extinguishing

FCP / housing	Design	Flooding zones	XCM7202-Z3	XCM2003	XT2001 remote
FC722					
Standard	All	--	--	--	--
Comfort	With power supply (70 W) and plan compartment	--	--	--	--
	With power supply (250 W)	1	With free operating add-on ¹	--	Possible
FC723					
Comfort	All	--	--	--	--
FC724					
Comfort	All	1	With free operating add-on ¹	--	Possible
FC726					
Large	All	--	--	--	--

¹ If an XCM7202-Z3 cannot be installed, an XT2001 must be used.

Product documentation

Title	Document ID
System description	A6V10210355
Product data	A6V10210368
Planning	A6V10210362
Mounting/Installation	A6V10210390

Related documents such as the environmental declarations, declarations of conformity, etc., can be downloaded from the following Internet address:

www.siemens.com/bt/download



Technical data

Card cage (1 sector exting.) FCA2046

Plug-in units	Slots	1x extinguishing card XCI2005
Supply	Operating voltage	DC 20...30 V
	Maximum current	9.5 A
Connections	Supply input connector	X1, X2
	Extinguishing card socket strip	X100, X101, X102
	Flat cable socket strip for XBUS (blocking and addressing)	X700, X701
	Flat cable socket strip for module bus	X500, X501
	Input connector strip	X11, X12
	Output connector strip	X11, X14, X15, X16
	Connector strip for internal and external extinguishing terminals	X10
	Admissible conductor cross-section of the terminals	0.5...2.5 mm ²
Mechanical data	Dimensions (L x W x H)	296 x 70 x 105 mm
Ambient conditions	Operating temperature	Min. -5 °C max. +50 °C
	Storage temperature	Min. -20 °C max. +60 °C
	Air humidity	Max. 93 % rel. air humidity (EN 60068-2)

Extinguishing card XCI2005

Supply input	Voltage from card cage FC2046	DC 20...30 V
	Operating current	90 mA
	Maximum current	6.5 A
All outputs	Maximum current per card	4 A
Monitored outputs	Valve, standard, and inverse outputs	Max. 10
	Output voltage	Max. 25.8 VDC
	Output current	Max. 2 A, short-circuit-proof
	Load capacitance	Max. 470 μ F
	Line resistance	Max. 80 Ω , both conductors
	Monitored for	Ground fault, leakage current, open line
	Cable connection, via card cage	2-pin, max. 2.5 mm ²
Pyrotechnic valves	Load resistance	<ul style="list-style-type: none"> • Min. 2 Ω • Max. 32 Ω
Solenoid valves	Load resistance	<ul style="list-style-type: none"> • Min. 14 Ω • Max. 1000 Ω
Station and extinguishing battery, in same area	Cable length	Max. 30 m, if station and extinguishing battery in same area Max. cable resistance: Load-dependent
	Monitoring	Direct monitoring
	Valves	Max. 10/output <ul style="list-style-type: none"> • Pyrotechnic: serial • Solenoid: parallel
Station and extinguishing battery, in different areas	Cable length	Max. 400 m, if station and extinguishing batteries in different areas Max. cable resistance: Load-dependent
	Monitoring	Direct monitoring
	Valves	Max. 1/output
Standard output	Termination resistor	Min. EOL 40 Ω Max. EOL 4000 Ω
	Cable length	1000 m or 80 Ω Max. cable resistance: Load-dependent
Inverse output	Termination resistor	Min. 18 Ω Max. 1300 Ω
	Cable length	1000 m or 80 Ω Max. cable resistance: Load-dependent

Collective inputs, monitored	Collective inputs	Max. 4, can be configured as monitored inputs
	Open-circuit voltage	DC 15.9...21.1 V
	Alarm voltage	DC 4.8...12.5 V
	Quiescent current	5.3 mA, typical
	Alarm current	44 mA
	Number of devices per input:	Max. 8, collective
	'Manual release'	Max. 8 DM1103-L (yellow)
	'Emergency hold'	Max. 8 DM1103-S (blue)
	End-of-line	18 V voltage reference EOL
	Line protocol	Collective
	Line resistance	Max. 80 Ω , both conductors
	Load capacitance	Max. 300 nF
	Monitored for	Ground fault, leakage current, open line
	Cable connection, via card cage	2-pin, max. 0.65 mm ²
Monitored inputs		Max. 6; 10 if collective inputs not used
	Possible input circuits, configurable	<ul style="list-style-type: none"> • 'Normally open' • 'Normally closed' • 'Simple switchable' (sector valve) • 'Complex switchable' ('Automatic blocked', 'Manual blocked', 'Automatic blocked' and 'Manual blocked') • Loss of agent
	Line resistance	Max. 80 Ω , both conductors
	Monitored for	Leakage current, open line, ground fault
	Termination resistor	3.3 k Ω
	Cable connection, via card cage	2-pin, max. 0.65 mm ²
'Loss of agent' outputs, not monitored	Driver outputs	6
	Circuit	Open drain, short-circuit-proof
	Current limiting	40 mA
	Monitored for	Ground fault
	Supply output	DC 25.8 V
	Output current	Max. 1 A, short-circuit-proof
	Cable connection, via card cage	1x per output 2x for supply output Max. 0.65 mm ²

Extinguishing terminal output	Protocol	RS485, half-duplex
	Number of participants per sector	<ul style="list-style-type: none"> • Primary 1 • Secondary max. 5
	Cable length	<ul style="list-style-type: none"> • Primary max. 10 m • Secondary max. 1200 m
	Data rate	57.6 kbit/s, twisted, unshielded
	Monitored for	Ground fault
	Supply output	<ul style="list-style-type: none"> • Primary: V_{sys}, max. 1 A, short-circuit-proof • Secondary: V_{sys}, max. 2 A, short-circuit-proof
	Cable connection, via card cage	2x 2-pin bus connection 2x 2-pin bus supply output Min. 1.5 mm ²
XBUS connection	Protocol	XBUS, half-duplex
	Number of participants	Max. 16
	Cable length	Max. 6.5 m, ribbon cable
	Data rate	57.6 kbit/s
	Cable connection, via card cage	2x flat cable, 0.08 mm ² (28 AWG)
LEDs	Number: 29	H1...H30, 2x status LED 10x output, monitored 10x input, monitored 6x output, not monitored
Addressing		Automatic via card cage
Connections	Connector strip for card cage	X100, X101, X102
Mechanical data	Dimensions (L x W x H)	260 x 114 x 28 mm

Extinguishing terminal XTO2001

The extinguishing terminal XTO2001 is installed in the following components:

- XT2001 extinguish. terminal (remote)
- XCM7202-Z3 exting. terminal (1 sector)

Supply input	System supply	Via card cage FC2046
	Remote for XT2001:	Via power supply FP120 or FP2015
	• Monitoring signals	Mains, Batt
	• Ground fault monitoring (via switch S102)	
	• Third power supply source [FR]	DC 8...30 V
	Voltage	DC 12...30 V
	Operating current	18 mA typical @ DC 24 V
	Maximum current	250 mA @ DC 12 V
Data transmission		Half-duplex RS485
	Addressing via DIP switch S201	Address 1...7
	Cable length	Max. 1200 m
	Cable cross-section	Min. 1.5 mm ²
	Data rate	57.6 kbit/s with cable unshielded and twisted at 1200 m
	Monitored for	Ground fault, via PMI
	Number of participants	Max. 6 per extinguishing card
	Termination resistor	120 Ω EOL, on the last (most distant) extinguishing terminal
LEDs	Number	34 LEDs RGB
		4x 5 x 7 dot matrix LED, red
Connections	RS485, terminal	X1, 4 pin
	Supply, terminal	X2, 8-pin